



Storage Mixer

SSM-160U



Refer carefully to the manual before operation.

SSM-U Series

■ Coding Principle

SSM - xxxU - xx

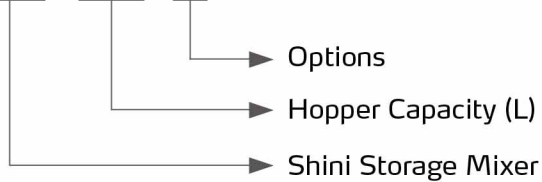

■ Features

- Vertically mounted blending screw and cylinder ensure even mixing of materials.
- Removable top assembly (lid, motor, and control box) for easy cleaning.
- Auto-stop timer function.
- Equipped with main power switch and safety interlock to ensure operator's safety.
- The durable stainless steel hopper is made from a single piece and has a unique spinning process.
- Detachable design enables quick disassembly of the hopper body, cone, and suction box for easy cleaning.

■ Application

SSM-U is mainly used for mixing plastics such as raw materials, masterbatch and recycled materials. SSM-U can not be used dealing with plastic powder and all kinds of foods, chemicals, and inflammable, explosive and volatile materials. Bulk density should be taken into account when the dimension of material is uneven or in other forms. Collocated with suction pipe for convenient material transport .

■ Working Principle

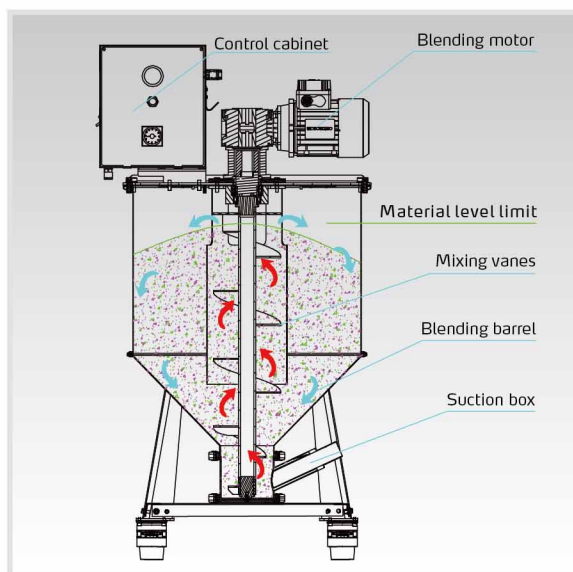

Outline Drawings

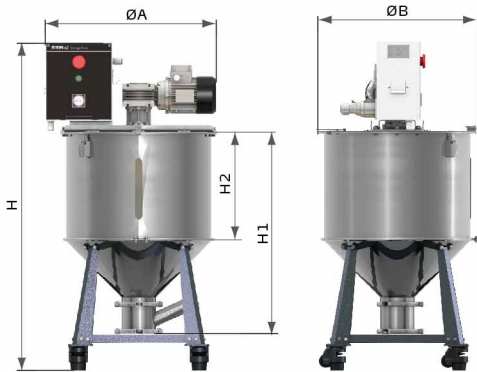

Specifications

Model			SSM-80U	SSM-160U	SSM-300U	
Motor Power (kW)			0.55	0.55	1.1	
Max. Throughput	kg/hr		200	400	800	
	lb/hr		441	882	1763	
Blending Barrel *	L		80	160	300	
	gal		21	42	79	
Dimensions	H	mm	1131	1385	1487	
		inch	44.5	54.5	58.6	
	H1	mm	748	816	940	
		inch	29.5	32.1	37	
	H2	mm	400	402	450	
		inch	15.8	15.8	17.7	
	ΦA	mm	654	785	935	
		inch	25.8	30.9	36.8	
	ΦB	mm	586	726	847	
		inch	23	28.6	33.4	
	Weight	kg		64	85	115
		lb		141	187	254

Notes: 1) "*" stands for the optimal mixing time at full load is about 15min.

2) Max. noise level is 70dB (A).

3) Max. mixing capacity is tested based on continuous processing material of 0.65kg/L(5.5lb/gal) in bulk density and 2~3mm/0.08~0.12inch in size.

4) Power 3Φ, 230 / 400 / 460 / 575VAC, 50 / 60Hz.

We reserve the right to change specifications without prior notice.

Shini Group

Addr: No. 23, Minhe St., Shulin Dist.,
New Taipei, Taiwan

Tel: +886 2 2680 9119

Fax: +886 2 2680 9229

Email: shini@shini.com

Factories:

- Taiwan
- Dongguan
- Pinghu
- Ningbo
- Chongqing
- Pune